

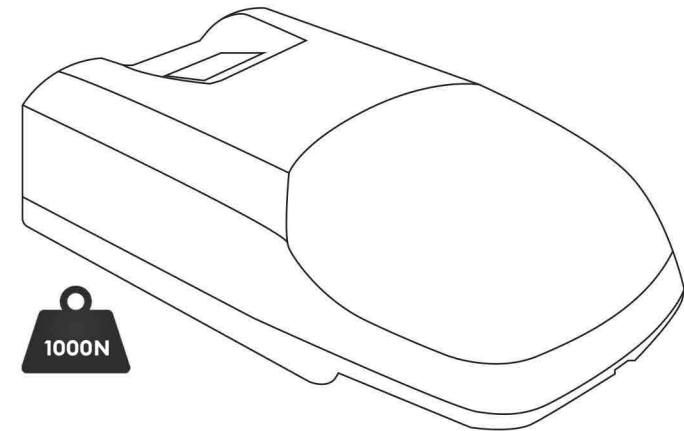

**YOUR KEY TO AUTOMATION** ↔



# GD-1000N

**AUTOMATIC SECTIONAL GARAGE OPENER  
USER'S MANUAL**

**WARNING: IT IS VITAL FOR THE SAFETY OF ALL PERSONS INSTALLING AND USING THIS OPENER TO FOLLOW THE INSTALLATIONS AND SAFETY WARNINGS. FAILURE TO COMPLY MAY RESULT IN SERIOUS PERSONAL INJURY AND/OR PROPERTY DAMAGE AND FAILURE OF THE OPENER SYSTEM.**

**ALTECH AUTOGATE INT. PHILIPPINES INC.**

B6 L28 Aphrodite St., Villa Olympia 6  
San Pedro, Laguna 4023

@Altech Autogate | @Altech Enterprise



☎ +63 917 870 9928  
+63 917 182 0156

☎ (02) 8398-5669

✉ autogate.ph@gmail.com

🌐 www.altech.ph

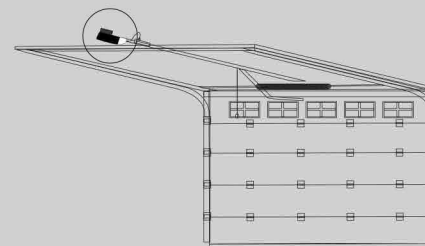







11.2	Examination Guide		
11.2.1	Problem	Causes	Solution
11.2.2	The chain is noisy.	The chain is too loose.	Adjust nut-M8 of the motor rail.
11.2.3	The motor does not work.	The socket is not well connected or the fuse is broken.	Check the socket or replace the fuse.
11.2.4	After setting open and close positions, the motor does not work.	The screws of fixing the Hall components are loose or program mistakes.	Tighten the screws or resetting open and close positions.
11.2.5	The door can't be closed.	Photo beam function works.	Cancel the photo beam function, referring to 9.1.
11.2.6	The wall button works well, but the transmitter doesn't work.	No transmitter learning or transmitter battery is power off.	Code referring to 10.1 or change new transmitter battery.
11.2.7	Transmitter distance is too short	The transmitter battery is nearly powered off.	Change new battery

### 3. Control panel and Transmitter



### 4. Optional Terminals and Connections

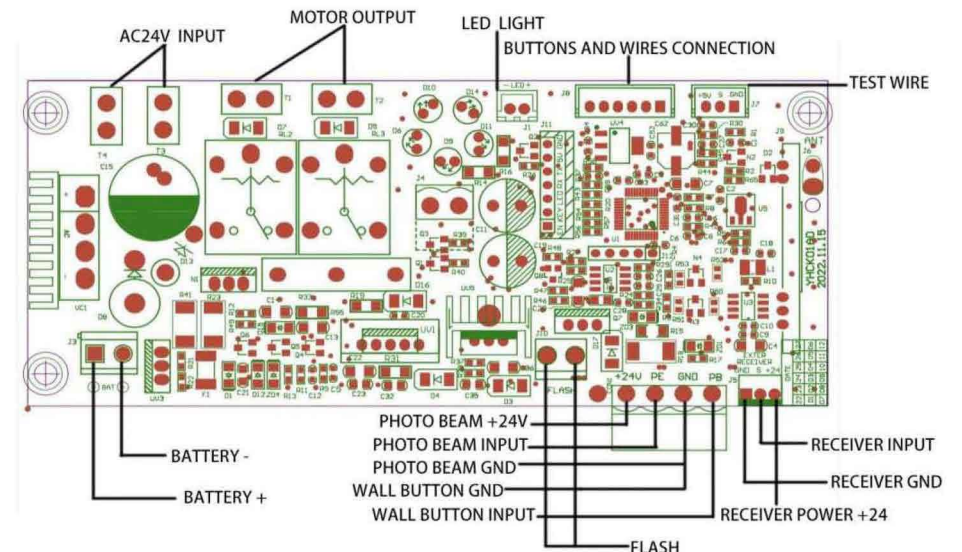

#### NOTE:

1. IF PHOTO BEAM WITH TWO WIRES, ONLY CONNECT "PE" AND "GND".
2. IF PHOTO BEAM WITH THREE WIRES, CONNECT "24V", "PE" AND "GND".

## 5. Installation of the garage door opener

### Step-1:

Open the box and prepare all parts. Check that all parts are present according to the below picture



### Step-2:

Attach the coupling (see pictures below) to the plastic disc in the toothed belt rails. Use the 4-screws provided. The lever points in the direction where the engine will be placed. The sliding block can be moved by pulling the lever up to release the lock (a pin falls into the holes in the toothed belt drive, this is the lock of the door when closed). Make sure that the sliding block falls well on the cam, the connection is good if the sliding block can no longer be moved on the toothed belt drive, with the lever loose.



### Step-3:

working parts are in good working condition or not.

### Manual Disengagement

The opener is equipped with a manual release.

Cord is to disengage shuttle and move door by hand while holding the handle down. Pull on the handle to disengage the shuttle. To re-engage the door simply run opener in automatic mode or move door by hand until the trolley engages in the chain shuttle.

In some situations that a pedestrian door is not in state, it is recommended that an external disengagement device should be fitted.

## 11. Owners' Guide

11.1	Attention in use	
11.1.1		At the first time of using the door, please test the driving system to see if it moves well. (Test method: unlock the trolley, pull and push the door by hand.)
11.1.2		Connected with the appropriate power and socket by professionals, and connected the earth wire with earth.
11.1.3		Using the transmitters in your sight. Do not stand or walk under a moving door. The transmitters should be out of reaching of children.
11.1.4		Make sure the door out of fire, moisture, electromagnetism and some other places.
11.1.5		Check at least twice a year to make sure the door is properly balanced and that all working parts are in good working condition. Adjust the tensile force of chain. Add suitable amount of lubricant to the active.



**9.2.4)** Press button SET to confirm and quit while the correct time is setting.

**9.2.5)** Unnecessary to set again even the power has dropped.

### **9.3) LOCK DOOR:**

**9.3.1)** Press SET and hold, the LED will display a setting number from 1 to 4, release SET, and it is now in lock door mode.

**9.3.2)** Press UP, the LED display 1, lock door is effective. Press DOWN, the LED displays 0, unlock door is effective.

## **10. Self-learning Transmitter**

**10.1)** Press CODE, release until the LED displays Press a button on the transmitter, then release and press again, the dot will flash to confirm the code.

**10.2)** Repeat step 1 to code a maximum of 25 different transmitters' and/or buttons.

**10.3)** To delete all stored codes, press and hold CODE, the LED displays dot flash, keep more than 8 seconds until the LED display C, all the settings of the transmitters are deleted.

## **Maintenance**

No particular maintenance is required for the logic circuit board.

Check the door at least twice a year if it is properly balanced, and all

Now attach the motor to the toothed belt rails with the 2-brackets below and tighten it with the nuts. ATTENTION: Tighten the nuts (by hand), so do not tighten them too tightly!

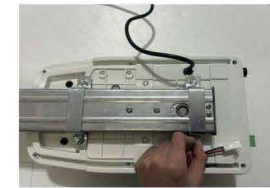

### **Step-4:**

Use the part below and attach it above door, according to the instructions below.



### Step-5:

Attach the rails to the support above the door using the nuts below.

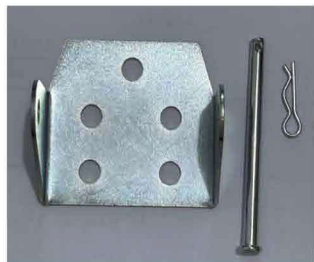

### Step-6:

Now take the parts below. This secures the drive to the ceiling.

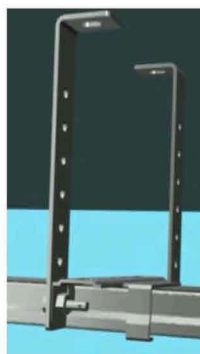

### Step-7:

Attach the bracket below to the garage door. Place it in the middle of the garage door at the top. The flat side of the bolts is on the outside of the garage door. If you have an insulated garage door, you can also secure it with e.g. (sturdy) self-tappers, so that nothing has to be drilled through the door (self-tappers are not included!).

**8.4)** When the door is hindered, it will rebound 15-20cm.

## 9. Function Modes

The unit has three selectable functioning modes, PHOTO BEAM, AUTO CLOSE DOOR and LOCK DOOR.

### 9.1) PHOTO BEAM:

**Make sure the photo beam has been installed correctly before setting the PHOTO BEAM function.**

**9.1.1)** Press DOWN and hold until the LED displays, then LED display H or II automatically according to the original state.

**9.1.2)** If the LED displays H, press DOWN once, the LED displays II, the photo beam is now enabled.

If the LED displays II, press UP once, the LED displays H, the photo beam is now enabled.

**9.1.3)** Press SET to confirm and quit.

### 9.2) TO SET AUTO-CLOSE ON/OFF:

**9.2.1)** Press UP and hold until the LED displays.

**9.2.2)** Press UP button once, the auto close time increase 1 minute. Press DOWN button once, decrease the auto close time 1 minute. The LED displays the current set value.

**9.2.3)** The Auto Close function will be disabling when the setting time is 0.



2 .Now it is the time to set the closed position.

**7.5)** Press and hold DOWN, the door will travel to the close position.

**7.6)** If the door has overrun its position, press the UP to move the door upwards. Adjust the position by pressing DOWN and UP.

**7.7)** Press the SET to confirm.

The door will now open and close automatically to map the opening and closing sensitively driven by force.

**WARNING: Keep all persons and property away from the door during the installation process.**

**7.8)** Now the door is set in normal operational mode.

**IMPORTANT NOTE: Safety systems must be checked regularly to ensure that maximum safety is maintained at all times.**

## 8. Adjustments

**Normally, the force settings are automatically set, and the force can be adjusted by an authorized professional opener installer for special purposes if it is necessary.**

**8.1)** Press SET and hold, the LED will display a setting number from 1 to 3, release SET, it is now in force adjustment mode.

**8.2)** Press UP to increase the force one-degree, and press DOWN to decrease one degree (maximum degree is 9 and the minimum is 1).

**8.3)** Press "SET" button to confirm.



### Step-8:

Now take the following with the 2 corresponding screws and bolts. Assemble the two arms together. The curved side is attached to the door side. The straight piece acts as an extension and can be mounted in various positions. It depends on the distance to the door. The extension can also be omitted.



### Step-9:

Mount the L-arm by means of the splits on the bracket on the door and secure it with the locking pin.



Attach the L-arm by means of the 2nd split to the handle in toothed **belt**

drive and secure it with the locking pin.



#### **Step-10:**

Attach the cord to the release. In the event of a power failure or failure of the engine, the door can be disconnected from the drive and opened manually.



### **6. Programming the Unit**

**The system must be checked and tested when connections are completed.**

**6.1)** Check the chain support if it is halfway to make sure the movement is problem free in both opening and closing.

Make sure that the door disconnected the motor, and doors category have been observed.

**6.2)** Now carry out a test of the door disconnected the motor, and open and close the door to verify that the mechanical parts are all in good working order and the door not bound in its tracks.

**6.3)** Check that all the safety devices on the unit are working properly (emergency stop, photo beam, etc.). This is one of the most important checks and must be done with great care; in fact, the active safety of the automatic door depends on the correct functioning of the safety devices. The reversing sensitivity device is of great help in minimizing damage but only the correct installation of the safety devices will make it possible to stop the door before it can cause any damage or injury to person and/or property.

**6.4)** it is now time to set the opening and closed position.

### **7. Setting Open and Close Positions**

**7.1)** Press and hold "SET" until the LED displays the letter 1. It turns into opening state.

**7.2)** Now press "UP" again and hold, the door will travel to the open position, release the button when the door has reached the desired position.

**7.3)** If the door has overrun its position, press DOWN to move the door downwards. Adjust the position by pressing "UP" and "DOWN" buttons.

**7.4)** Press SET to set the open position, the LED will display the letter