

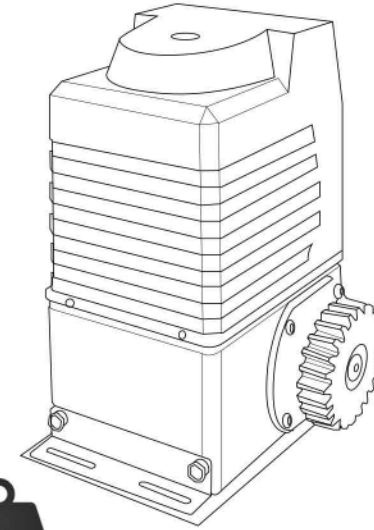

YOUR KEY TO AUTOMATION ↔



SL-2202

AUTOMATIC SLIDING GATE OPENER
USER MANUAL

ALTECH AUTOGATE INT. PHILIPPINES INC.

B6 L28 Aphrodite St., Villa Olympia 6
San Pedro, Laguna 4023

@Altech Autogate | @Altech Enterprise



☎ +63 917 870 9928
+63 917 182 0156

☎ (02) 8398-5669

✉ autogate.ph@gmail.com

🌐 www.altech.ph

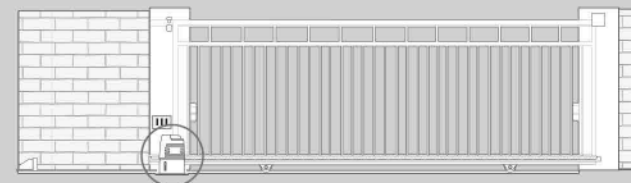

NOTES

I. Important Safety Information:

- * The gate operator should be installed by qualified technician; otherwise, serious personal injury or property damage may occur.
- * When opening or closing the gate, do not attempt to walk or drive through the gate.
- * Children should not be allowed to play near or operate automatic gates.
- * Install the gate operator on the inside of the property. Do NOT install it on the outside of the property where the public has access to it.
- * Be careful when in close proximity to moving parts where hands or fingers could be pinched.
- * The operator should be switched off before repairing it or opening its cover.

II. Sliding Gate Opener Main Functions:

The gate operator is used to drive the sliding gate. It is featured with powerful starting strength, capable of overload in a short time. When overloaded, it will be protected electrically. In the event of power failure, an emergency release key allows you to operate the gate manually.

- * Totally integrated electrical mechanical system (excludes racks)
- * Single button control circularly /three buttons control can be choosed
- * Control board interface for optional impact-proof infrared photocells
- * Alarm lamp interface
- * Automatic delayed closing
- * Pedestrian mode
- * Adjustable resistance sensitivity
- * Gate will auto stop and re-open when an obstacle is encountered
- * Wireless remote control or wired remote control are optional

III. Technical Specifications:

Power Supply: AC110V/220V± 10v, 50-60Hz	Motor Power: 400w
Gate Moving Speed: 18m/min	Output Torque: >22N.m
Limit Switch: Magnetic	Gross Weight: 11KG
Environment Temperature: -10°C - +55°C	Loading weight: 2000 KG

IV. Preparing The Installation Site:

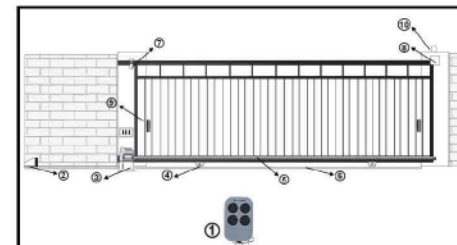

Figure 1

1. Remote Control
2. Rubber Stopper
3. Sliding Gate Opener Motor
4. Roller
5. Gear Rack
6. Ground Track
7. Guide Bracket
8. End Catcher
9. Photocell Sensor (optional)
10. Flashing Light (optional)

NOTES

V. Working Principle and Main Structure

The dimension is shown in Fig. 2. The gate operator is composed of a single-phase motor, worm and worm gear. The main shaft of the motor rotates the worm with the clutch engaged, the worm rotates the worm gear and output gear, which pushed racks attached to the sliding gates, thus moving the gate.

The structure of motor and worm is shown in Fig 3. Output torque can be adjusted by pressure screw, tighten (or release) the pressure screw to increase (or decrease) the output torque.

The worm gear components are shown in Fig 4. It includes a pair of plastic gear clutches. In case of power failure you can use key to release the clutch, then the gate can be moved manually.

The gate operator is well lubricated and cooled by the cooling oil, which fills the whole gate operator, including the stator, the rotor of the motor, the worm gear and the worm.

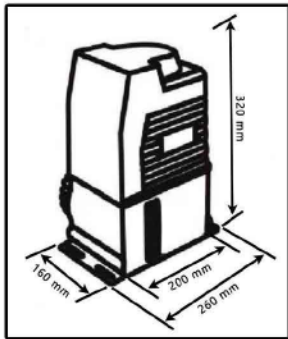

Figure 2

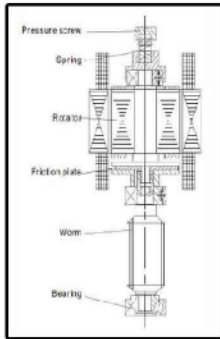

Figure 3

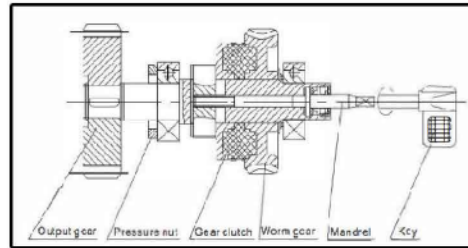

Figure 4

VI. Installation

The gate operator operates by forcing a drive rack past a drive gear. To guarantee the safety, it is highly recommend to install limit switch to prevent the gate from sliding out of the rails. The rails must be installed horizontally.

Conduit

In order to protect the wires, conduit must be preset into the concrete when it is poured. Wires within the conduit shall be located or protected so that no damage can result from contact with any rough or sharp parts.

Concrete Pad

The base unit of the gate operator requires a concrete pad in order to maintain proper stability. The concrete pad should be approximately 350mm*300mm*350mm deep in order to provide for adequate operation.

Anchors

You can use the anchor bolts anchors, washers, and nuts. These anchors must be set into the concrete when it is poured, or you can use wedge anchors.



OPTIONAL ACCESSORIES FOR YOUR AUTOMATIC GATE

FLASHING LIGHTS



- AL-03
FLASHING LIGHT
- AL-04
FLASHING LIGHT W/ BUZZER
- AL-06
FLASHING LIGHT W/ ANTENNA

REMOTE CONTROLLERS



- RC-12G
REMOTE CONTROL
- SM-24LT
REMOTE CONTROL WITH CLIP
- HPRC-10
LONG DISTANCE RC TRANSMITTER
- RC-12BG
REMOTE CONTROL
- RC-12C
REMOTE CONTROL CLIP HOLDER
- ST-03
WIRELESS WALL MOUNTED TOUCH SWITCH

RECEIVERS



- JS-092
INDOOR RECEIVER
- JS-084
OUTDOOR RECEIVER
- JS-093
INDOOR EXTERNAL RECEIVER
- SGC-01
WIFI GATE RECEIVER CONTROLLER

SAFETY AND SECURITY



- WPC-01
WIRELESS WATERPROOF KEYPAD
- HW-06
INFRARED PHOTOCELL SENSOR

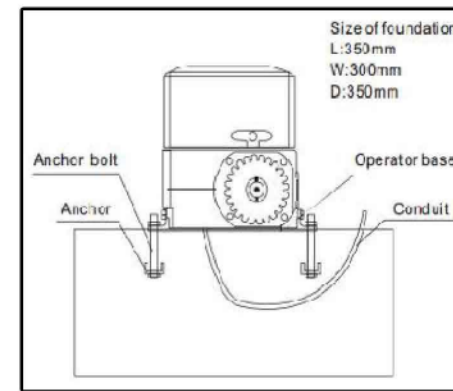

Figure 5

Operator Base

Mount the gate operator base to the concrete pad.

Operator

Mount the gate operator to the base using nuts and washers. Verify that the operator is leveled properly.

Installation of Rack (see Fig 6)

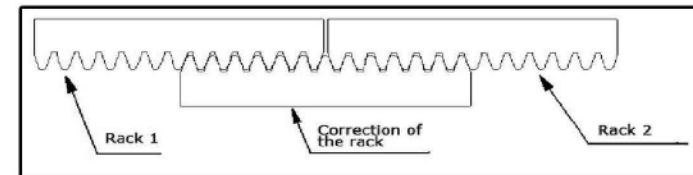

Figure 6

Installation of Limit Magnet

There are 2 limit magnet supplied. Note there is a left hand and a right hand magnet. The magnet should be installed one at either end of the rack. See Fig 6

To install the magnet in the correct position, open the clutch door and press the 'CLOSE' button on the remote, the motor will run but will not drive the gate. Close the gate manually and adjust the limit magnet to contact the toggle switch and switch the motor off at the desired gate position. To adjust the stop position to of the gate when it is open, press the 'OPEN' button, manually open the gate and adjust the other limit magnet to contact the toggle switch and switch the motor off.

When you are satisfied the limit magnet are in the correct positions, tighten the screws in the limit magnet to clamp them to the rack, close the clutch door and using the remote control check the gate opens and closes to the desired positions. Adjust the limit magnet if necessary.

Manual operation (see Fig 3)

If the gate has to be operated manually due to a power cut or malfunction of the automated system, use the release key, as follow:

- * Fit the supplied key in the hole
- * Turn the key to release the clutch
- * Open and close the gate manually.

Note: If the gate bumps the mounting post and cannot be electric opened, move the gate back a few inches manually, thus you can release the operator with the key

VII. Installation Diagram of Electrical Parts

7.1. Terminal 6 and 7 for connecting to 220V power

7.2. Connect to sliding gate motor (Fig 10)

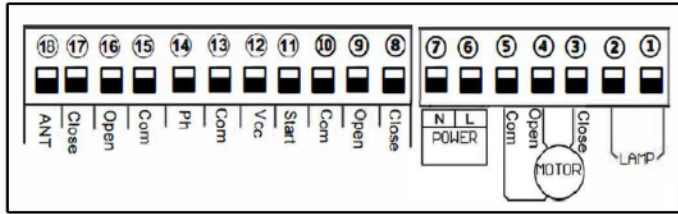

Figure 9

Terminal 3, 4, 5 is for connecting motor wire.

Terminal 3, 4 determines the forward and backward direction of the motor

Terminal 5 is terminal for Com (GND)

Note: Our factory setting is install motor on the right of gate! When you want to install motor at the left of gate ,please exchange 3 and 4 motor wire. After exchange, please check if the motor can close and stop normally. If can't ,please up or down the "J1" to the opposite direction. ("J1" includes two pcs short circuit caps, you need to adjust the caps simultaneously, then it will work)

7.3. Connect to flashing light . (Fig 11)

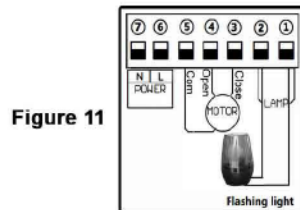

Figure 11

Terminal 1 and 2 is for flashing light.

AC220V power output, flashing light on when motor start running, after motor stop 30s, the flashing light will turn off

7.4. Terminal 8, 9 and 10 is for external limit switch .

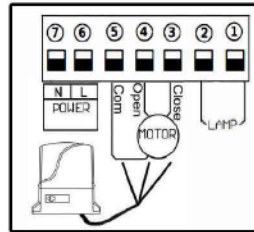

Figure 10

8.7 Terminal stop detection interface:

Terminal for limit switch, such as spring limit or magnetic limit .

8.8 Power switch:

Switch on/off power stop when do some setting on the control board

IX. Troubleshooting

Problem	Possible causes	Repair method
Gate fails to operate	<ol style="list-style-type: none"> 1. Check the clutch states ,power-driven state or not 2. Power no indication, and power trip. 3. The fuse has broken 4. Remote control failure or invalid 5. Damaged power cable 6. Remote control or motor problem 	<p>Recovery</p> <p>To restore power</p> <p>Change the fuse</p> <p>Detection or change</p> <p>Detection and Repair</p> <p>Detection and Repair</p>
Working distance of remote control reduced	<ol style="list-style-type: none"> 1. Low battery power or damaged 2. Interference from equipment using the same frequency 3. The receiver of controller was damaged 	<p>Replace battery</p> <p>Wait eliminate interference</p> <p>Replace the control board</p>
Gate fails to stop at start or end position	<ol style="list-style-type: none"> 1.The terminal stop toggle switch is damaged or obstructed. 2. Limit switch of the motor and the limit detection of the interface PCB board plug off. 3. Limit of open and close is in wrong position. 	<p>Replace toggle switch or remove obstruction</p> <p>Insert and fixed it</p> <p>Adjust of limit switch(K1)</p>
Press open and close key of motor, but cant working and operate	<ol style="list-style-type: none"> 1. Blocked sensitivity is too high(set too big) 2. The gate has lifted off the track and disengaged the drive gear from the rack 	<p>Make blocked sensitivity lowered ,and check gear and racks can operate normally.</p> <p>Maintenance and replace.</p>

X. Important Notes

1. When there's obstructions between the gate, do not open or close the door to ensure safety.
2. The power supply for the control board should be equipped with a separate switch with a fuse rated at 10AMP.
3. There is strong electricity in the control box. Please cut off the power supply before opening the cover.
4. Motor gear modulus $M = 4$, number of teeth = 16, use the corresponding racks
5. The gate should be as straight as possible, making sure after racks fixed good and the gate can be in a good position with motor gear.
6. Racks and gear should be controlled in good gap. so can make sliding steady.
7. After confirming the direction of gate movement, please check if the limit block fixed in good position to avoid the motor run out of control due to failure

C. Dial-up 3 & 4: Auto close time setting

Auto close function activated after gate complete open to its place and stop by limit switch

Dial-up 3 & 4, OFF-OFF: Auto close function disabled(Factory setting)

Dial-up 3 & 4, ON-OFF: 105

Dial-up 3 & 4, ON-ON: 305

Dial-up 3 & 4, OFF-ON: 605

D. Dial-up 5 & 6: Auto close time setting when pedestrian mode activated

When remote control triggers the pedestrian mode (remote control button 2 or 4), the gate will stop after open 6s. If auto close function activated, the gate will auto close after gate open to 6s. Auto close time setting as follows:

Dial-up 5 & 6, OFF-OFF: Auto close function disabled(Factory setting)

Dial-up 5 & 6, ON-OFF: 55

Dial-up 5 & 6, ON-ON: 105

Dial-up 5 & 6, OFF-ON: 305

Note:

1. When the motor is running, the motor will stop immediately if triggers pedestrian mode

2. After triggering the pedestrian mode to open the gate for 6s, no matter it enter the countdown to close the gate or stop status, If trigger again, the gate will close the gate immediately.

E. Dial-up 7: Condominium mode setting

OFF: Condominium mode disabled(factory setting)

ON: Condominium mode activated

When the gate is opening, trigger remote control and the start interface are invalid until the door is opened. When the gate is closing, trigger remote control and the start interface, the gate will stop to close and auto open until the opening limit is reached (the remote control and the start interface are invalid when the gate is opening).

E. Dial-up 8: Remote control buttons mode

OFF: Single button control circularly

First button control gate open, stop, close, second button use for pedestrian mode

ON: Three buttons control

First button control gate open, second button control gate stop, third button control gate close, fourth button use for pedestrian mode

Note: Please choose the remote control mode firstly before remote control code learning to control board

8.4 Learn remote control code:

A. Control panel can memory more than 50 pcs remote control

B. Code learning: Press board "LEARN" button, LED indicator light on, press remote control first button, LED indicator flash twice, code learning succeed. If no remote control signals received within 2.6s, the receiver will automatic quit learning functions.

C. Code clearing: Press and hold the button 6 seconds, LED indicator flash twice, all the code that has been memorized in control board will be cleared

8.5 Motor Start Capacitors:

Capacitors are connected with control board before use motor, please confirmed the interface of capacitors is secure. Please see picture Fig 16

8.6 Limited switch options (J1):

Limit switch is used to switch terminal stop detection interface, that direction of open and close the gate

7.5. Connect to infrared sensor. (Fig 12)

Figure 12

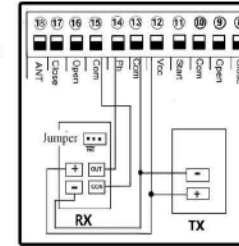

Connect terminal 15 to the COM of photocell RX.
Connect terminal 14 to the OUT of photocell RX.
Terminal is supplying power for external device.
Connect terminal 12 to the "+" of photocell RX and TX.
Connect terminal to 13 the "-" of photocell RX and TX.

7.6. Connect to start terminal. (Fig 13)

When you don't want to use the remote control to control the gate. Terminal 11 is for you connect some external device, such push button, wired keypad, receiver etc.

Control gate open, stop, close.

Figure 13

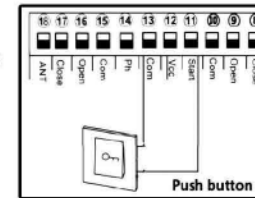

Example for push button;
Terminal 11 and 13 connect to push button.

7.7. Connect to open device. (Fig 14)

Terminal 16 is open only, for external device, such push button, wired keypad, receiver etc.
Only control gate open

Figure 14

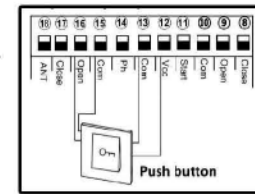

Example for push button;
Terminal 15 and 16 connect to push button.
Terminal 12 and 13 to supply power for push button

7.8. Connect to close device. (Fig 15)

Terminal 17 is close only, for external device such push button, wired keypad, receiver etc.
Only control gate close

Figure 15

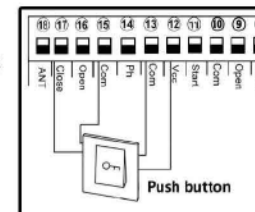

Example for push button;
Terminal 15 and 16 connect to push button.
Terminal 12 and 13 to supply power for push button

VIII. Function Testing

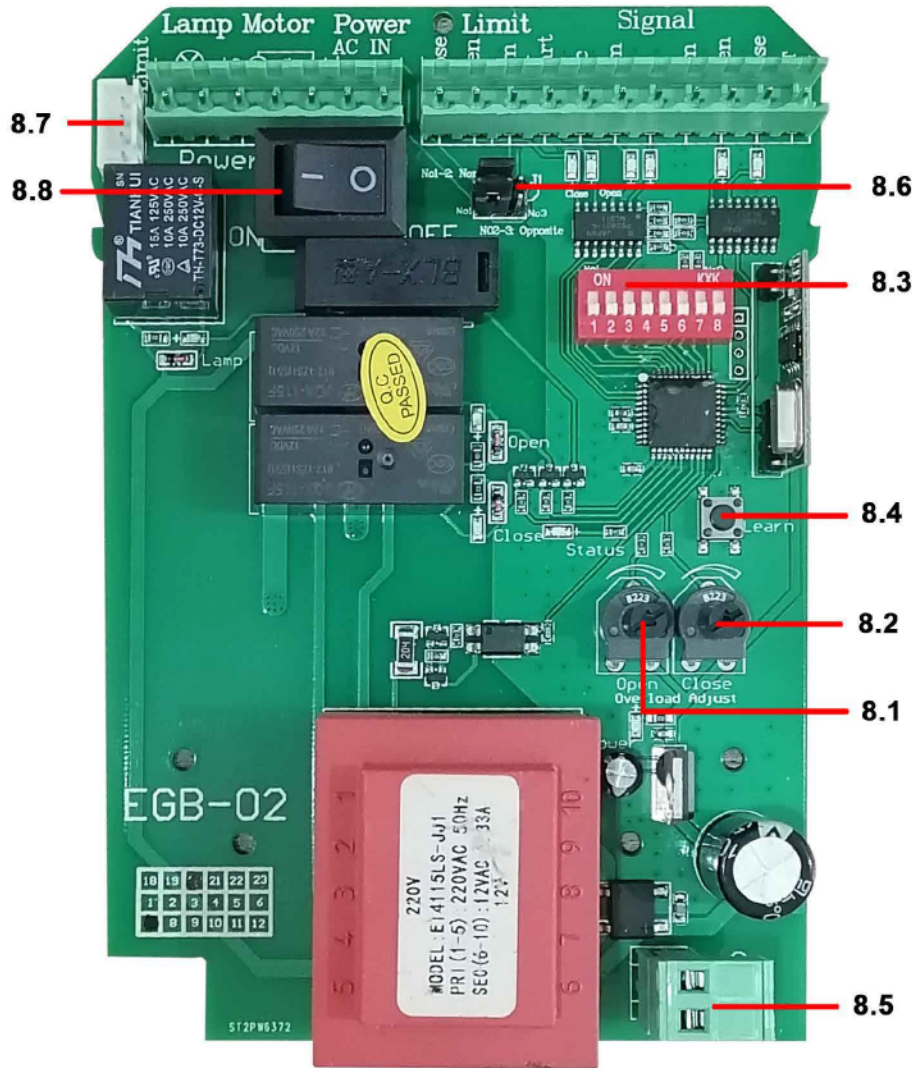

Figure 16

- | | |
|-------------------------------|---------------------------------|
| 8.1: Adjust Open Sensitivity | 8.5: Connect to Start Capacitor |
| 8.2: Adjust Close Sensitivity | 8.6: Limit Switch Option |
| 8.3: Programming Setting | 8.7: Terminal Stop Detection |
| 8.4: Learning Button | 8.8: Power Switch |

The following functions refer to the picture Fig 16

8.1 Gate open blocked detection:

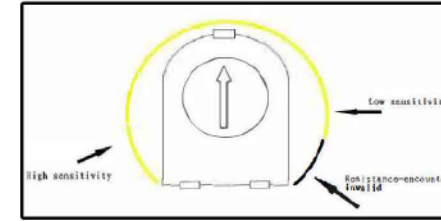

Figure 17

As picture show, we can rotate "Open overload " potentiometer to adjust the motor open sensitivity of blocked
 A. High sensitivity: when the motor is rotation, will meet some minor resistance, then control board will send a signal to let motor stop rotating.

B. Low sensitivity: when the motor is rotation, will meet greater resistance, then control board will send a signal to let motor stop rotating.

C. As picture show, when pointer rotate to black part ,the control panel will quit this system

8.2 Gate close blocked detection:

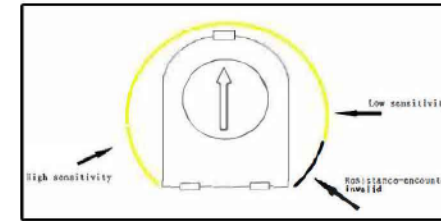

Figure 18

As picture show, we can rotate "Close adjust" potentiometer to adjust the motor close sensitivity of blocked
 A. High sensitivity: when the motor is rotation, will meet some minor resistance, then control board will send a signal to let motor stop rotating.

B. Low sensitivity: when the motor is rotation, will meet greater resistance, then control board will send a signal to let motor stop rotating.

C. As picture show, when pointer rotate to black part ,the control panel will quit this system

8.3. programming setting:

A. Dial-up 1: Limit mode optional

OFF: NC mode(Factory setting)

ON : NO mode

Limit switch direction setting(J1):

Normal :Short circuit cap simultaneously No1 and No2 of J1 (Factory setting)

If motor system install at left of gate . Please adjust the J1 ,short the cap simultaneously No2 and No3

B. Dial-up 1: Infrared mode

OFF: NC mode(Factory setting)

ON: NO mode

If the gate meet obstacles during closing, It will auto stop and auto open. After the gate complete open to its place, it will auto close again if the obstacle disappear within 2s, if not , it will not auto close until the obstacle disappear.