

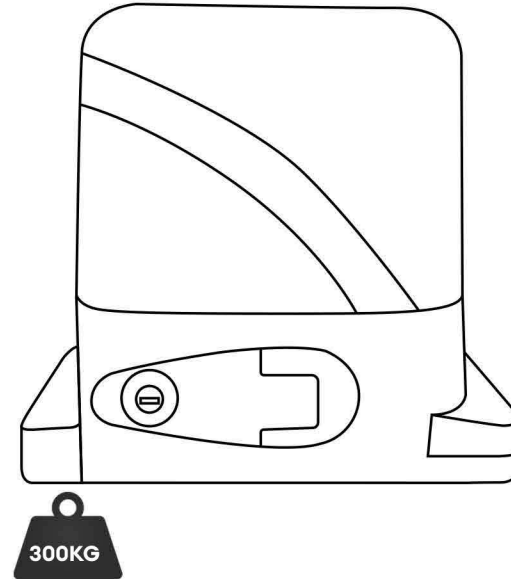

YOUR KEY TO AUTOMATION ↔



SL-2405A

AUTOMATIC SLIDING GATE OPENER (300KG)
USER'S MANUAL

ALTECH AUTOGATE INT. PHILIPPINES INC.

B6 L28 Aphrodite St., Villa Olympia 6
San Pedro, Laguna 4023

@Altech Autogate | @Altech Enterprise



☎ +63 917 870 9928
+63 917 182 0156

☎ (02) 8398-5669

✉ autogate.ph@gmail.com

🌐 www.altech.ph

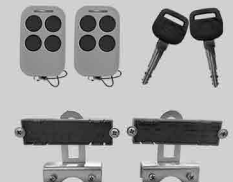
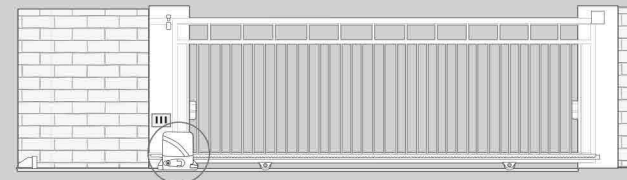

NOTES

1. Summary

This equipment is one of the auto gate openers launched by our company which adopt new design and integrated control system. Our new sliding gate opener has many features such as: low noise, light weight, powerful starting torque, stability, reliability and is compact and stylish. The motor will still work for a short period of time using lower voltage. The control board has overload protection. When there is a power failure, the motor drive can be separated by the use of the clutch, by using the specified key the user has the ability to disconnect the clutch enabling the gate to be opened or closed manually. Using the optional infrared photocells the gate will automatically stop and re-open if an obstacle is sensed.

2. Appearance and dimensions

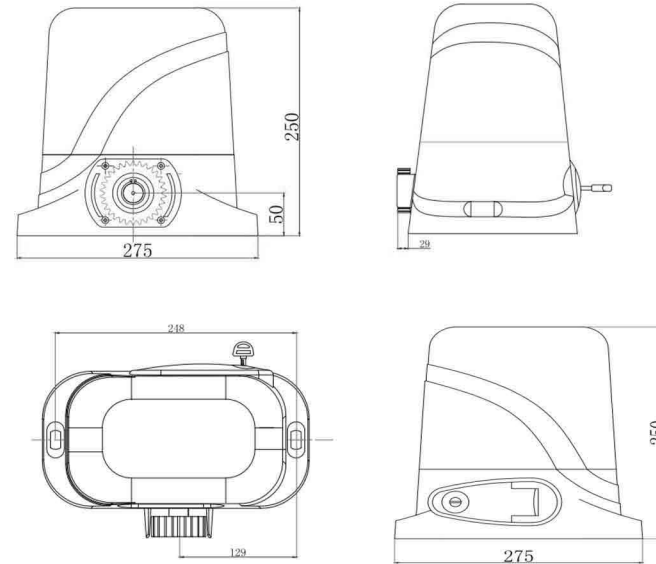

Diagram 1

3. Parameters

1. Working temperature of motor: $-25^{\circ}\text{C} \sim +55^{\circ}\text{C}$
2. Working humidity: $\leq 85\%$
3. Power supply: $220\text{VAC} \pm 10\%$ / $110\text{VAC} \pm 10\%$ 50Hz/60Hz
4. Motor voltage: 24VDC
5. Rated power: 200W
6. Output gear module: $M=4$
7. Output gear number: $Z=16$
8. Open(close) speed: $v=12\text{m/min}$
9. Rated speed : 1400RPM
10. Maximum pull: 1100N
11. Maximum load: 300kg
12. Net weight: 8KG
13. Remote control distance : $\leq 50\text{meter}$
14. Packing : In a standard carton
15. Protection class : B

After menu setting well, you could press [LRN] button to exit the menu setting and close the display.

Number		Range	Factory set	Board sign
P0	Soft start time	0~1s	1s	0:Soft start disable
P1	Low speed meet resistance	0~20 level	8 level	M LOW OVER LOAD
P2	High speed meet resistance	0~20 level	10 level	M HI OVER LOAD
P3	High speed running time	0~1 Level	0 (Close)	1:Hi-speed mode activate, PA,PB seting invalid if P3 set value 1
P4	Auto close time after swipe card to open gate	0~99s	10s	CARD-CLOSE AUTO CLOSE
P5	Pedestrian mode gate auto close time	0~99s	10s	
P6	Auto close	0~99s	0 (close)	AUTO CLOSE
P7	Pedestrian mode gate open time	0~20s	5s	PED
P8	Single button mode (key4)	0~1	0 (close)	ONE KEY
P9	Alarm lamp output control	0~1	0 (close)	ALARM
PA	Slow speed time during gate opening	0~5s	2S	
PB	Slow speed time during gate closing	0~5s	2S	
PC	RESET			RESET

5.5.Auto travel learning

Note: Before the auto travel learning, The gate should always in close limit position(close limit indicator is off). Any interruption happen during the auto travel learning process will cause the failure.

Steps: Move the gate to close limit position, press and release the button“FUNC” 5 times, you can hear a long beep from the buzzer on board, the motor will start working a complete cycle of open/close. During the auto travel learning process, the digital display will show the working time of the complete working cycle, and after the gate moving to the close position, another long beep can be heard, display goes off. The board will automatically set the high speed and slow speed working time based on how much time you set for slow speed in PA and PB, When installation the actual gate may cause the time error, please adjust PA and PB to prevent it.

When the set time on PA and PB is quite different from the actual running time.Please repeat the above learning step.

When the learning time in a certain direction is lower than 3S or the learning time difference of two directions is more than 5S, auto travel learning operation fails.

NOTE: right motor function condition should be like: when gate opening, blue indicator LED lit up; when gate closing, red indicator LED lit up. Only the gate on the right function direction, then could realize the swipe card, infrared, PED mode etc function.

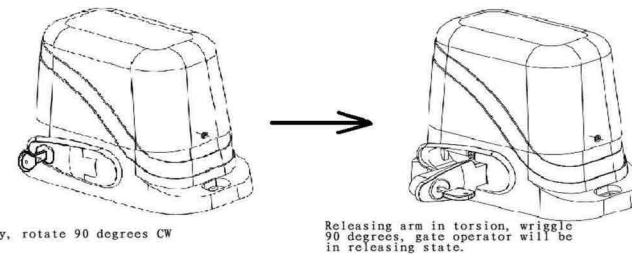

Diagram 4

4.6 Installation of infrared sensors(photocell)

1. Unscrew the screws on the motor and the remove the motor cover.
2. Let the signal line and power line coming in from outside ,and then connected it according to electrical wiring diagram
3. With screws fixed base plate in a fixed position
4. Close the motor cover and tighten screws
5. According to the required to adjust the transmitter and receiver height position
6. After installation,to test photocell and adjustment.to make sure can normal work.

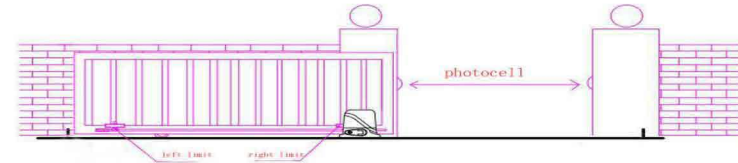

Diagram 5

5.Control board program

5.1.Parameter

1. Board power supply: AC 24V, could connect 24V back up battery, 24V output for external device
2. Use for DC sliding gate motor
3. Transmitter: Giant rolling code transmitter, support max 120pcs transmitter
4. 24V DC motor
5. Feature: digital display; limit; resistance sensitivity adjustable; motor speed adjustable; motor high speed time adjustable; motor protection time 60s; auto close function; auto close time adjustable; board single button control mode; resistance infrared; gate close infrared; PED mode; alarm lamp output; swipe card.

5.2. Installation diagram of electrical parts.

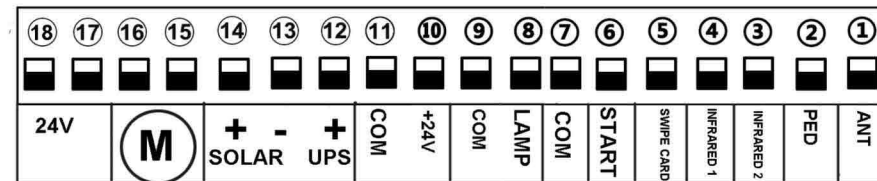

Diagram6

- 1.ANT terminal:Antenna connection
- 2.PED terminal:used for connect external device control opening pedestrian mode. The gate will open partially .
- 3.Infrared 2 :used for connecting photocell. After there is no infrared sign detected 2s , the gate will auto close and bounce again once meet resistance.

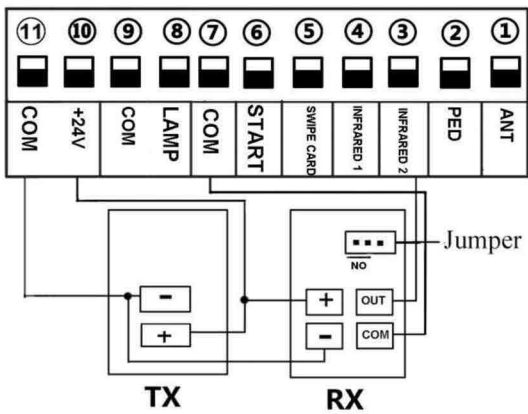

Diagram 7

Connect terminal ⑦ to the “COM “of photocell RX.
 Connect terminal ③to the “OUT “of photocell RX.
 Terminal ⑩ and ⑪is supplying power for external device.
 So, connect terminal ⑩ to the “+ “of photocell RX and TX.
 Connect terminal ⑪ to the “- “of photocell RX and TX.

4. Infrared 1: used for connecting photocell. When gate closing, if meet resistance, gate will stop and open

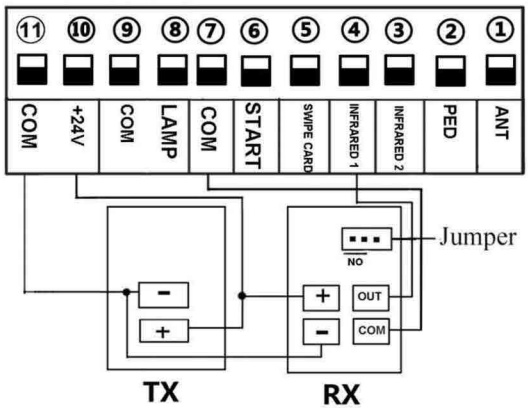

Diagram 8

Connect terminal ⑦ to the “COM “of photocell RX.
 Connect terminal ④o the “OUT “of photocell RX.
 Terminal ⑩ and ⑪is supplying power for external device.
 So, connect terminal ⑩ to the “+ “of photocell RX and TX.
 Connect terminal ⑪ to the “- “of photocell RX and TX.
 5. SWIPE CARD: used for connecting swipe card system (low voltage)

	now matching successfully.
Single button control mode START	Through digital display to control single button mode, “0” means close single button mode, “1” means open single button mode. When single button mode close, the three buttons of transmitter control the ”open-stop-close” separately; When single button model open, just the button 1 control the ”open-stop-close” cyclically
Pedestrian mode PED	Through digital display control the PED time, “0-20s” option, “0” means close PED mode. Through remote button 4 or PED button which on the board to control the PED mode gate open
MOTO Intelligent change speed system	motor has high speed, slow speed, slow stop. And high speed running time could be adjusted through digital display. P3 set to 1: activate Hi-speed function, motor runs with full high speed P3 set to 0: The system will auto assign the high speed running time after customer set PA and PB soft stop time and auto travel learning, Soft start running time 0-1s adjustable.
Limited and Resistance functions	Limit: during the motor is running, the motor will stop running after reaching open & close limit Meet Obstacle: If meet obstacle when opening the door, the door will stop. If meet obstacle when closing the door, the door will stop then bounce back; sensitivity of resistance can be adjusted through digital display.
Auto close	auto-closing function only activated after the open limit switch enabled Auto close time adjustable through digital display from 0-99s; There are three kinds of auto close : 1. auto close after gate opener under normal remote control 2. auto close after swipe card 3. auto close after gate open under PED mode. when the auto-closing time starts countdown, the indicator blinks every 1 second to indicate
INFRARED mode 1 (meet resistance infrared)	When gate closing, motor sense INFRARED mode 1 sign, then should stop running at once and bounce open. After stay open 2s, it would auto close, now the auto close not control by the auto close time. When gate opening, the INFARED model 1 not effect.
INFRARED model 2 (gate close infrared)	When gate open or on opening, once the gate close infrared sense person or car have already pass 2s, gate motor would close; When gate closing, gate motor would bounce once sense the infrared sign and would close again until not sense the infrared sign 2s
Alarm lamp output	Through digital display to control the alarm lamp output method, factory set 0; 0 means lamp terminal with DC24V output except after gate total close 30s. 1 means lamp lit up when gate running, lamp lit off when gate closing
Motor protection	Motor running continuously over 60 seconds, the motor stops running for protecting the motor.

5.4. Digital display setting

Note: Only under gate in stop condition and not in auto close count down condition, it permits to enter the menu setting and code learning.

Press and hold the [FUN] button until the digital display shows PO. Now you enter the menu setting. You could through adjust the [INC+] [DEC-] to increase or decrease the serial number or numerical value. After data adjust well then press [FUN] to store the data. With one sound of buzzer, the store successfully.

5.3.Function testing

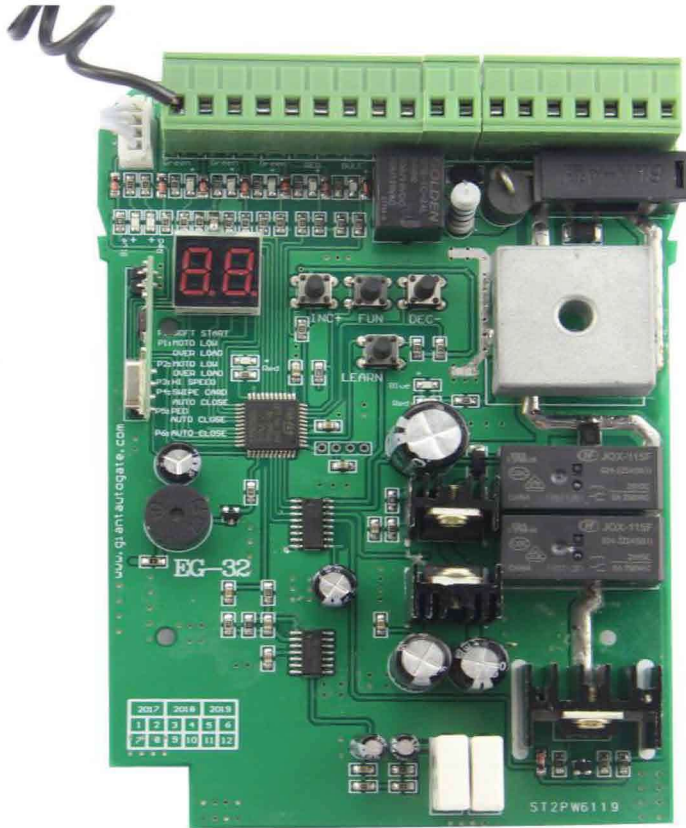

Diagram 16

Status Indicator LED	After control panel power on, the status indicator LED lit up.
Motor open-close instruction	Blue indicator LED lit up means gate opening. Red indicator LED lit up means gate closing.
Transmitters	Encoding format: Our own custom rolling code. Three buttons on the remote control are used to control the door open, close and stop. Single button control mode, operate the door as “open-stop-close-open”. Maximum memory capacity of control panel: 120PCS transmitters. Could customized to match with EV1527 remote (better with three remote buttons)
Code learning	Press learning button at least 1second and then release, the LED indicator will go out, now press the button of remote control, if LED indicator blinks 4 times, the transmitter succeeded in learning to panel, if the control do not receive any signal from transmitter within 5s, the LED indicator lit up, now exiting learning mode.
Code clearing	Press and hold down learning button for at least 5 seconds(the LED indicator goes out during this process), the LED indicator will light up to indicate code has been removed successfully.
Transmitter copy (Giant rolling code transmitter)	The copy remote not need learning, it could directly use with the gate opener. When use the copy remote first time, need long press the remote about 5s until digital display shows the remote number. Then indicator lit up twice, buzzer beep,

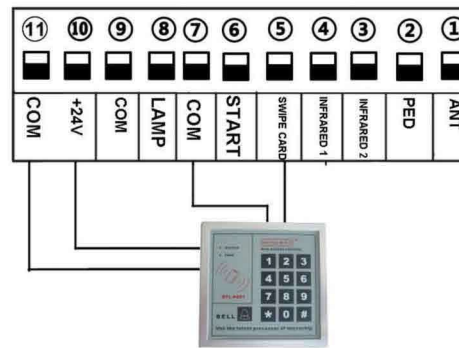

Diagram 9

Example for wired keypad;

Terminal ⑤ and ⑦ connect to wired keypad.

Terminal ⑩ and ⑪ to supply power for wired keypad..

6.START terminal :Single button control mode switch, used for controlling gate “open-close-stop-open-close” cyclically, (Note: if hold press the button for long time would effect some other function)

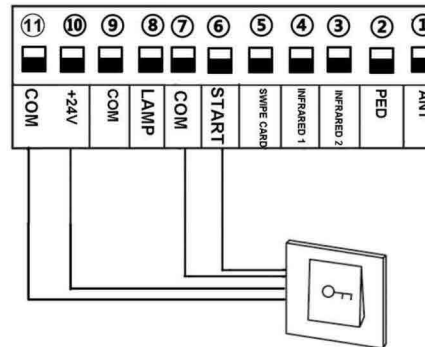

Diagram 10

Example for push button;

Terminal ⑤ and ⑦ connect to push button.

Terminal ⑩ and ⑪ to supply power for push button.

7.COM Terminal: use for connect COM terminal or GND

8&9. Lamp terminal: use for connect flashing light. Lamp light on when gate running. Output voltage is DC24V

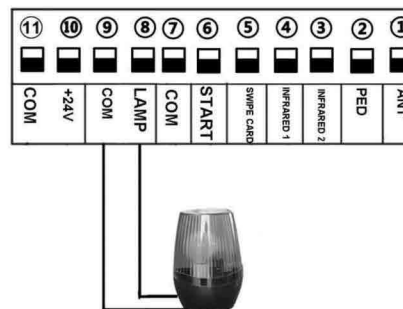

Diagram 11

Terminal ⑧ and ⑨ is for flashing light .

10&11 . +24VAC terminal: .DC24V on board power supply for infrared external device

12&13. UPS terminal:

A. used for connecting back up battery, which could be charged by electric supply power. Charge current is 20-50mA. The battery would supply the power automatically when without the electric power supply. When UPS supply power to board, the standby current is 20mA, the current is about 5-10A when motor running.

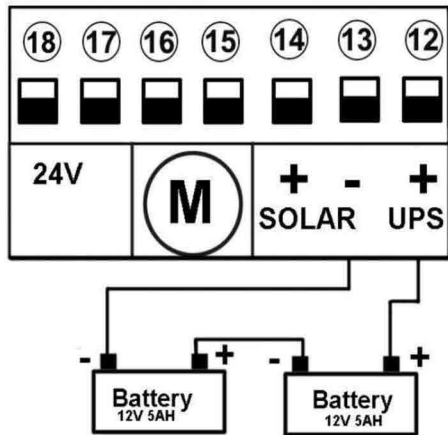

Diagram 12

EG-32 control board accept 24VDC battery power input .So connect two 12V battery in series.

a , Connect battery 1 “+” to battery 2 “-”

b. Connect battery 1 “-” to terminal ⑬

Connect battery 2 “+” to terminal ⑫

B.Work with solar system. Diagram as follows

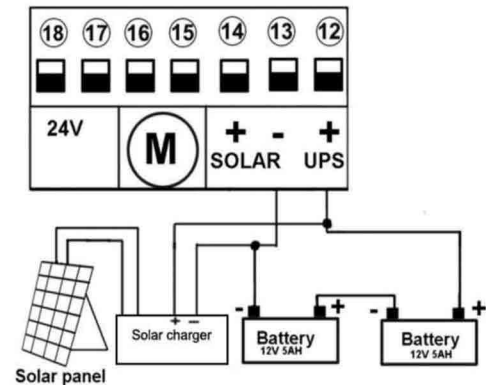

Diagram 13

a.Connect 2 pcs 12V battery in series into 24V

b.Connect solar charger to 24V battery

c.Connect battery to control board UPS terminal ⑫ and ⑬

d. Connect solar panel to solar charger

15.&16.Motor terminal: use for connecting 24VDC motor .

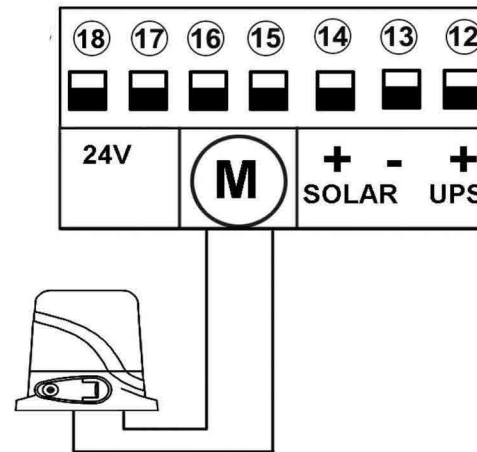

Diagram 14

Terminal ⑮ and ⑯ is for connecting motor wire.

Please note : Our factory setting is install motor on the right of gate! When you want to install motor at the left of gate ,please exchange ⑮and ⑯motor wire .

17&18 .24V terminal:used for connection transformer AC24V

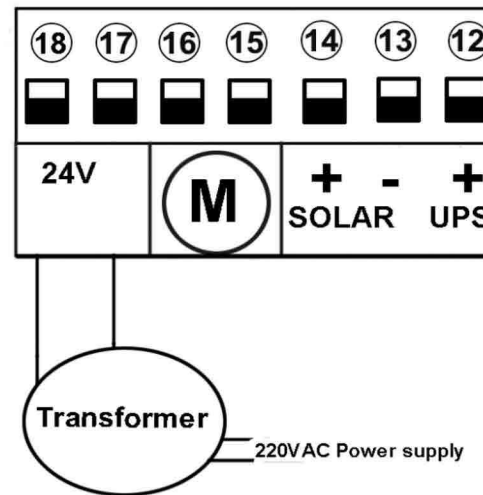

Diagram 15

Connect terminal ⑰ to transformer one yellow wire

Connect terminal ⑱ to transformer another yellow wire

Two red wire from transformer is for connecting 220V power supply.