

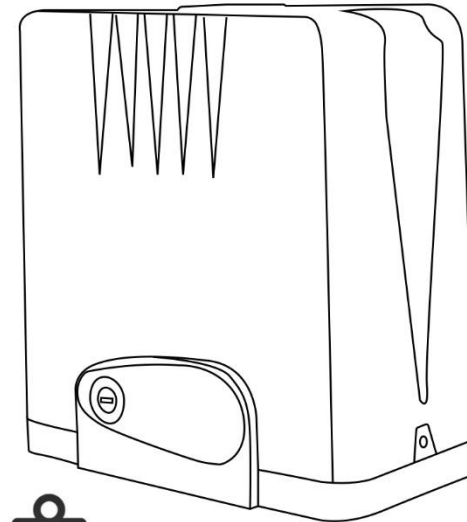

YOUR KEY TO AUTOMATION ↔



SL-2401 B

**AUTOMATIC SLIDING GATE OPENER
WITH BACK-UP BATTERY
USER MANUAL**

ALTECH AUTOGATE INT. PHILIPPINES INC.
B6 L28 Aphrodite St., Villa Olympia 6
San Pedro, Laguna 4023

@Altech Autogate | @Altech Enterprise



☎ +63 917 870 9928
+63 917 182 0156

☎ (02) 8398-5669

✉ autogate.ph@gmail.com

🌐 www.altech.ph

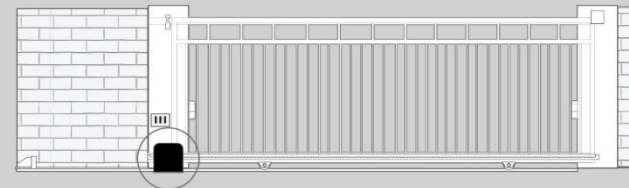

NOTES



CONTENTS

Technical specification & feature -----	2
Part list -----	2
Motor structure diagram -----	3
Typical installation layout -----	3
Factory setting motor open direction -----	4
General safety -----	4
Installation of the opener-----	6
Necessary tools-----	6
Caution -----	6
Example sliding gate setup -----	7
Installation procedures -----	7
Manual operation -----	8
Installation of the gear rack -----	8
Installation of limit magnet -----	8
Control board program -----	9
Parameter-----	9
Terminal and diagram of control board instruction-----	10
Push button connection-----	10
Photocell connection-----	10
Flashing light connection-----	11
Motor connection-----	11
Transformer connection -----	12
Battery and solar connection-----	13
Function details -----	13
Digital display setting -----	15
Board digital LED display -----	16

Technical Specifications & Features

Specifications:

- Power supply:
 Model B: 220V±10%, 50/60Hz
 Model S: Solar Power Panel 24v 30w
- Motor: 24VDC
- Absorbed motor power: 200W
- Gate moving speed: 15m/min
- Max gate weight: 1000KGS
- Environmental conditions: From -25°C to +50°C
- Protection class: IP44
- Dimensions: 42cmX42cmX27cm (L*W*H)
- Remote control distance: ≤30m
- Output gear module: M=4
- Output gear number : Z=16

Features:

- Easy to install and low maintenance.
- Quick selection for gate open/close direction.
- Emergency release key in case of power failure
- Stop/Reverse in case of obstruction during gate opening/closing
- Built in adjustable auto-close
- Can be equipped with wide range accessories
- Soft start soft stop
- Pedestrian mode
- DC all-in-one machine (control panel, transformer and battery built inside of motor) makes more convenient installation, more elegant.

Part list:

Model B with lead acid battery:

- | | |
|-----------------------|-----------------------------|
| 1* sliding gate motor | 2*remote control |
| 2* magnet | 2*manual release key |
| 4*expansion bolt | 2*lead acid battery 12V 5AH |
| 1*transformer | |



x1



x2



x4



x1

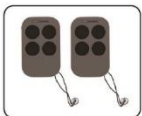

x2



x2



x2

NOTES

NOTES



Motor structure diagram Model B with lead acid battery:

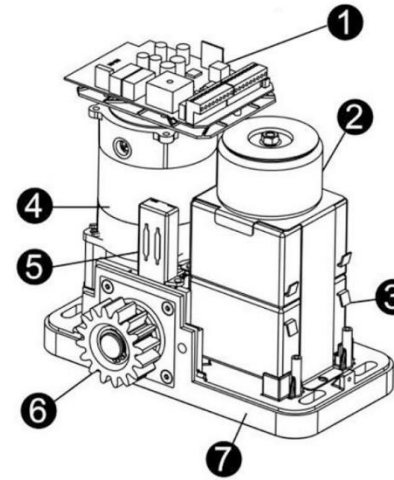

- 1 Control Board
- 2 Transformer
- 3 Lead-acid Battery
- 4 Motor
- 5 Magnetic Sensor
- 6 Output Gear
- 7 Aluminum alloy Base

Typical installation layout

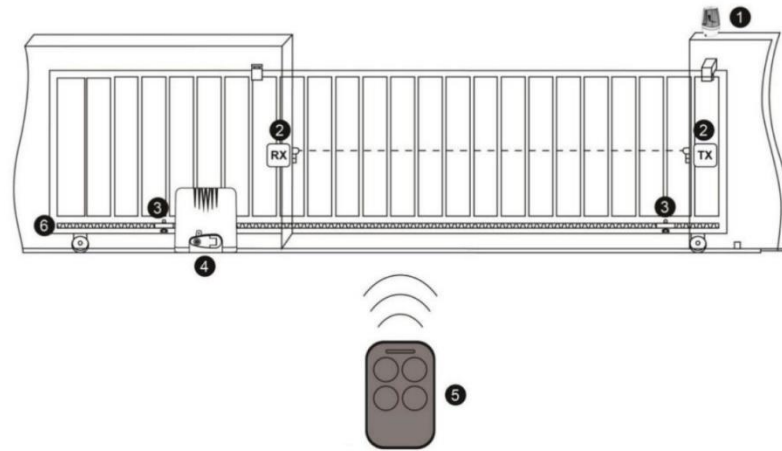

- 1 Flashing Lamp
- 2 Photocell
- 3 Magnet
- 4 Sliding Gate Motor
- 5 Remote Control
- 6 Gear Rack

Fig 5

Noted: Before Installing, test the motor by plugging it into a power and pressing the remote. You will see the motor cog turn. When it stops (after approx 1 minute), press the remote again to see it turn in the opposite direction. This will give you an understanding of the way in which the motor will move the gate

Factory setting motor open direction:

The gate motor will open the gate to the right-hand side as its default setting ,as below picture(Fig 6):

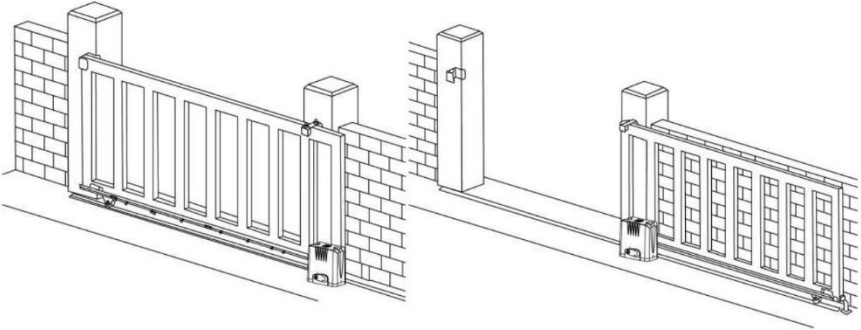

Fig 6

Gate in closed position

Gate in open position

If gate need to open to the left-hand , then motor need to be installed on the left side of gate, as below picture(Fig 7) showed,now you will need do below procedures:

- 1.Exchange motor open and close cable on the control board motor connection terminal
- 2.Swap over two magnets positions

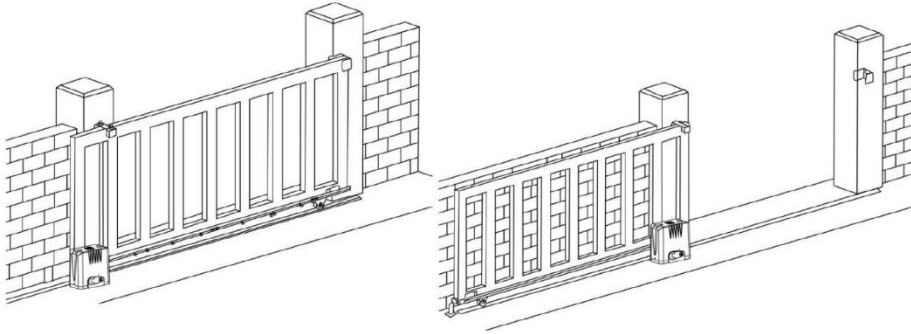

Fig 7

Gate in closed position

Gate in open position

Noted:Installation and safety precautions. These should be read carefully before installation and operation as they provide important information about safety,installation, operation and maintenance. This product complies with the recognized technical standards and safety regulations

General Safety

WARNING! An incorrect installation or improper use of the product can cause damage to persons, animals or properties.

- Scrap packing materials (plastic, cardboard, polystyrene etc.) according to the provisions set out by current standards. Keep nylon or polystyrene bags out of children's reach.

NOTES



		Factory set: 0	
P7	0-1	Limit mode option 0: NC mode 1: NO mode Factory: 0	
P8	0-1	Single button control mode 0: close 1: open Factory set: 0	
P9	0-1	Lamp control mode: 0: Mode 0 1: Mode 1 Factory set: 0	Mode 0: when gate moving, lamp light on; after gate stop 30s, lamp off; Mode 1: when gate moving, lamp light on; when gate stop, lamp off.
PU	0-1	start USB upgrade Factory set: 0	1: start USB upgrade
Po	0-10	Reset Factory set: 0	When choose value=5, then will reset the all value.

Board digital LED display:

1. When start gate opening, LED show 1S "OP"
2. When start gate closing, LED show 1S "CL"
3. After gate stop, LED show 1S "--"
4. When full open limit, LED show 1S "LO"
5. When full close limit, LED show 1S "LC"
6. When reach max working time, LED show 1S "EC"
7. After trigger overload protect, LED show 1S "OU"
8. After trigger photocell, LED show 1S "PH"
9. After trigger loop, LED show 1S "LP"

- This product was exclusively designed and manufactured for the use specified in the present documentation. Any other use not specified in this documentation could damage the product and be dangerous.
- The factory declines all responsibility for any consequences resulting from improper use of the product, or use which is different from that expected and specified in the present documentation.

- Do not install the product in explosive atmosphere.
- The factory declines all responsibility for any consequences resulting from failure to observe Good Technical Practice when constructing closing structures (door, gates etc.), as well as from any deformation which might occur during use.

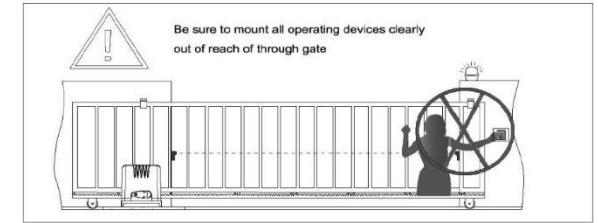

- Disconnect the electrical power supply before carrying out any work on the installation. Also disconnect any buffer batteries, if fitted.
- Check that a differential switch with a 0.03A threshold is fitted just before the power supply mains.
- Check that earthing is carried out correctly: connect all metal parts for closure (doors, gates etc.) and all system components provided with an earth terminal.
- Fit all the safety devices (photocells, electric edges etc.) which are needed to protect the area from any danger caused by squashing, conveying and shearing.
- The factory declines all responsibility with respect to the automation safety and correct operation when other supplier's components are used.
- Only use original parts for any maintenance or repair operation.
- Do not modify the automation components, unless explicitly authorized by the factory.
- Position at least one luminous signal indication device (blinker) where it can be easily seen, and fix a Warning sign to the structure (Fig 8).

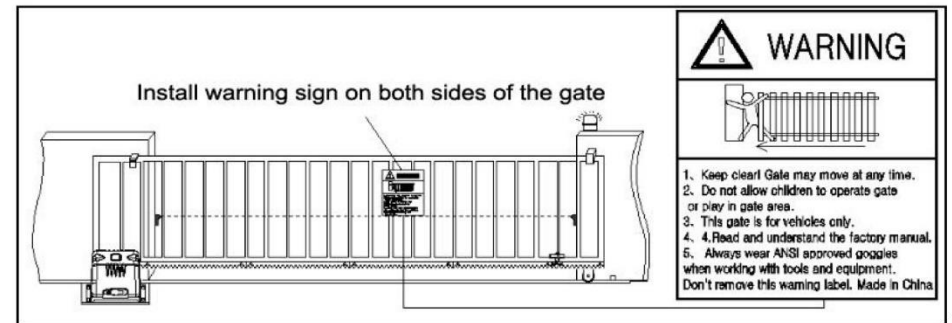

Fig 8

- Only use original parts for any maintenance or repair operation.
- Do not modify the automation components, unless explicitly authorized by the factory.
- Instruct the product user about the control systems provided and the manual opening operation in case of emergency.
- Do not allow persons or children to remain in the automation operation area.
- Keep radio control or other control devices out of children's reach, in order to avoid unintentional automation activation.
- The user must avoid any attempt to carry out work or repair on the automation system, and always request the assistance of qualified personnel.

- Anything which is not expressly provided for in the present instructions is not allowed.
- Installation must be carried out using the safety devices and controls prescribed by the EN 12978 standard.

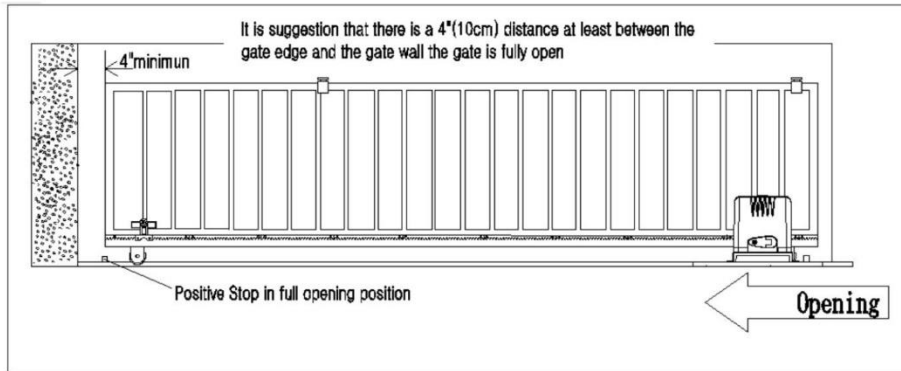

Fig 9

Installation of the Opener

Necessary Tools

- The following tools may be necessary to install the Gate Opener.
- Screwdrivers
- Electric drill
- Wire cutters
- Wire stripper
- A socket set

Caution

- Be sure that the opener is installed in a level and paralleled position and is properly secured and the gate can be moved smoothly push or pull by hand before installing motor(Fig 10)
- Improper installation could result in property damage, severe injury, and/or death.
- Before starting installation, ensure that there is no point of friction during the entire movement of the gate and there is no danger of derailment.
- Wheels and guide rollers should rotate easily and be free from dirt/grime.
- Ensure that the *Warning Signs* are present.

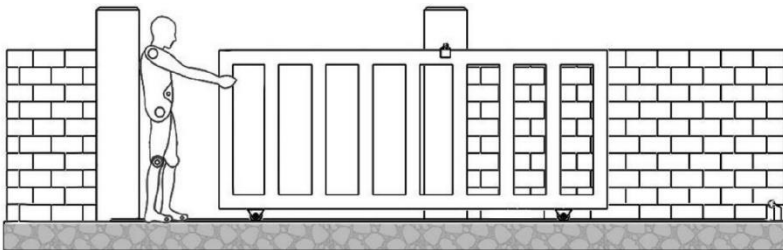

Fig 10

Intelligent charging function	Intelligent charging function
	1. When the battery voltage is less than $25V \pm 1$, the charging function will be started automatically.
	2. When the battery is fully charged, the charging circuit is automatically disconnected to prevent overcharging.
	3. When the system detects that the charging power supply is not connected, it will automatically disconnect the charging circuit.
	4. When the motor is running, automatically disconnect the charging circuit to protect the charging equipment

Digital display setting

Note: Only under gate in stop condition and not in auto close count down condition, it permits to enter the menu setting and code learning.

Press and hold the [FUN] button until the digital display shows PO. Now you enter the menu setting. You could through adjust the [INC+] [DEC-] to increase or decrease the serial number or numerical value. After data adjust well then press [FUN] to store the data. With one sound of buzzer, the store successfully.

After menu setting well, you could press [LRN] button to exit the menu setting and close the display.

Number	Value	Function	Description
P0	0-1	Soft start function 0: close 1: 1s Factory set: 1	Value 0 means without soft start; Value 1 means now soft start time is 1s.
P1	0-20 Level	Motor low speed running resistance sensitivity Factory set: 10	Value much bigger, resistance sensitivity much higher, then motor no easier to stop.
P2	0-20 Level	Motor high speed running resistance sensitivity Factory set: 10	Value much bigger, resistance sensitivity much higher, then motor no easier to stop.
P3	0-60s	High speed running time Factory set: 12	Value 0 means all low speed running time
P4	0-20s	PED mode gate open time Factory set: 5	Value 0 means close PED mode
P5	0-99s	Auto close time under PED mode Factory set: 10	Value 0 means close auto close time under PED mode
P6	0-99s	Auto close time	Value 0 means close auto close time

Code clearing	Press and hold LEARN button 5s until buzzer with long beep then release button, digital LED will show "00". After code clearing, all remotes will be unpaired.
Code learning	<p>1. Press LEARN button, instruction LED light on, then press remote button, with buzzer short beep, then means code learning successfully, digital LED will show the quantity that remote learned</p> <p>2. After press LEARN button, if no receive remote signal within 8s, instruction LED will turn off and exit code learning statue.</p> <p>NOTE: Because digital LED only two digits, if remote quantity number above 100pcs, then the tens digits and hundreds digits will replace with words "A". If remote quantity number above 110pcs, then the words will show "B". Max can support 120pcs remote. If digital LED show "-" with buzzer short beep for 5 times, then means can not learn more remote.</p>
Resistance functions	If meet resistance during gate opening, gate will stop; If meet resistance during gate closing, gate will reopen. The value of resistance sensitivity can be adjusted through board digital menu. Motor high speed and low speed running resistance sensitivity can set separately.
Limited functions	<p>1. When gate fully opened/closed, after trigger limit, motor will stop running.</p> <p>2. Limit mode can be set through digital LED menu</p>
Loop function	<p>1. When gate full opened or opening, if trigger loop, motor will automatic close after loop signal disappear 3s.</p> <p>2. When gate closing, if trigger loop, motor will reopen at once. And after loop signal disappear 3s, then gate start close.</p>
Infrared mode	When gate closing, if trigger infrared, gate will reopen at once. And when gate full open also after infrared mode signal disappear 3s, then gate start to close.
Automatic close function	<p>1. Only after gate reach full open limit, then will start auto close function</p> <p>2. When auto close start countdown, STATE LED will flash one time each seconds.</p> <p>3. Auto close time can be set through digital menu</p>
Pedestrian mode	<p>Remote 4th button can trigger PED mode. When trigger PED mode, gate will auto open; If open PED mode auto close, then will enter auto close count down and close gate after time end.</p> <p>PED mode gate open time and auto close count down time can set through digital menu.</p> <p>PED mode can't be activate when gate is moving.</p>
Lamp function	<p>Through board digital menu P9 can set lamp mode:</p> <p>Mode 0: when gate moving, lamp light on; after gate stop 30s, lamp off;</p> <p>Mode 1: when gate moving, lamp light on; when gate stop, lamp off.</p> <p>NOTE: No matter mode 0 or mode 1, lamp will light on also when auto close time counting down.</p>
Motor protection	Motor running continuously over 90 seconds, the motor stops running for protecting the motor.

Example Sliding Gate Setup(Fig 11)

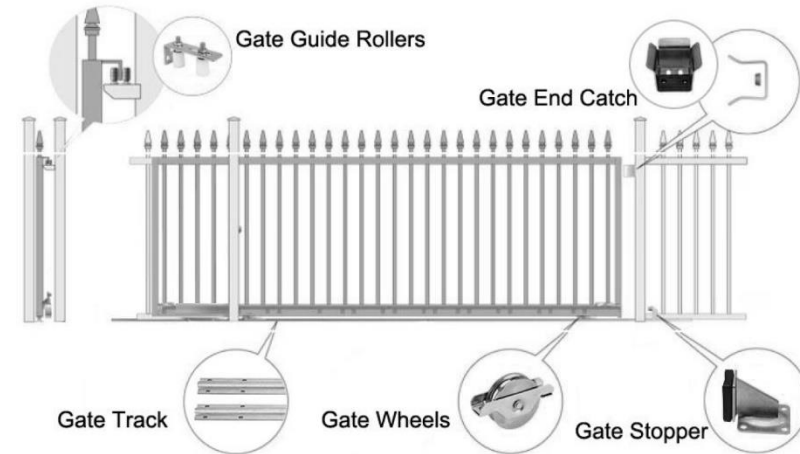

Fig 11

Note: Before motor installation, sliding gate must installed well with hardware kit. If any gate hardware kit require, please contact with us.

Installation procedures (Fig 12)

1. The limit default setting is for gate in close position. Before installation, please make sure gate is closed.
2. Prepare one or more conduits for the electrical cables. Cable conduits have to pass through the hole in the base plate.
3. Pour concrete and before it starts to harden, check that it is parallel to the gate leaf and perfectly level.
4. The four anchor bolts must be set into the concrete when it is poured, make sure the position of anchor bolts was placed according to the position of mounting holes on the base plate before concrete become harden.
5. Mount the base plate to the concrete pad.
6. Place the opener onto base plate. Check that it is perfectly parallel to the gate, and then screw the four bolts and washers supplied. It's only temporary installation. Further adjustment will be required when install the rack.

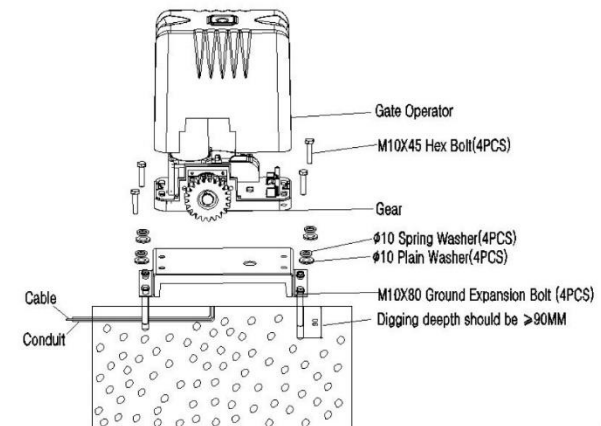

Fig 12

Manual Operation

The opener comes with an easy operating manual release. It brings the easiest manual release operation just in case of any emergency.

- Insert the manual release key supplied in package to release lock, then turning the key clockwise 90 degrees.
- Pull out the release lock part to be more than 90 degrees, now the gear and shaft are disengaged

Refer to the figures below(Fig 13)

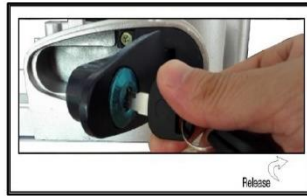
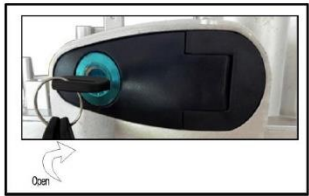

Fig 13

Installation of the Gear Rack

1. Start with gate in closed position
2. Gear rack length depend on gate length ,each gear rack is 1 metre. Put one end of rack on the output gear of motor as a temporary support. Make the rack horizontal and mark the rack mounting holes (three holes) on the gate .(Fig 14)
3. Weld the rack nut on the gate as mark and connect the rack to the gate using the bolt provided. Before weld, please keep 1.0mm space between the rack and the gear to avoid the weight of the gate effect on the opener.

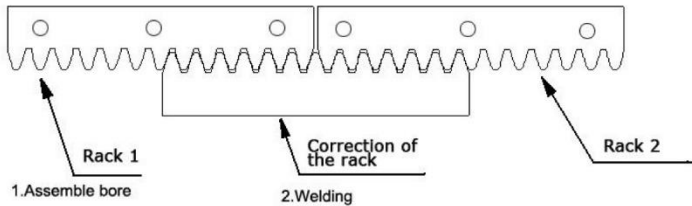

Fig 14

Installation of limit magnet

1. To ensure motor auto stop correctly , it is recommended to install limit magnet at both ends of rails to prevent gate run out of rails. The rails must be installed horizontally.
2. Two limit magnets supplied , blue one for open limit , red one for close limit .
3. Release the clutch with manual key and push the sliding gate manually to predetermine position, fix the magnet to gear rack and then tighten the clutch with key. Power on control board ,running the motor with remote control ,adjust magnet to proper position until the gate can auto stop at its correct position when full open or full close .



Fig 15

Important:

1. Check that the gear rack teeth engages with the gear teeth throughout the full distance. If not, adjust the

16&17 Power terminal: use for battery and solar system load.

A. Battery connect as below

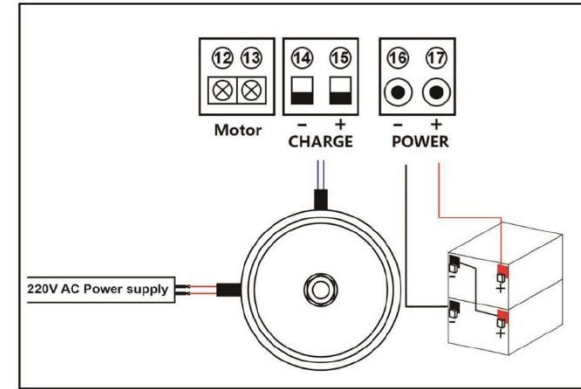

(Fig 23)

B. Detail solar system connect method as below:

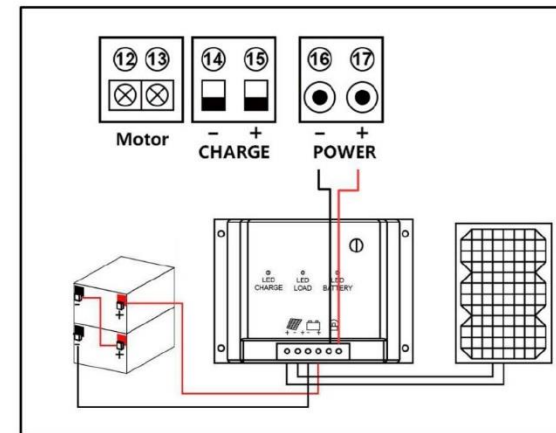

(Fig 24)

Function details:

Status Indicator LED	After control panel power on, the status indicator LED lit up.
Motor open-close instruction	Blue indicator LED lit up means gate opening. Red indicator LED lit up means gate closing.
Remote	Encoding format: Our own custom rolling code. 1. Single button control mode: remote first button to cycle control gate as "open-stop-close-stop", 4 th button to control PED mode. 2. Three button control mode: remote 1 st button to control gate open, 2 nd button to control gate close, 3 rd button to control gate stop. 4 th button to control gate PED mode. 3. Maximum memory capacity of control panel: 120PCS transmitters.

B. Install the motor on the left of gate.

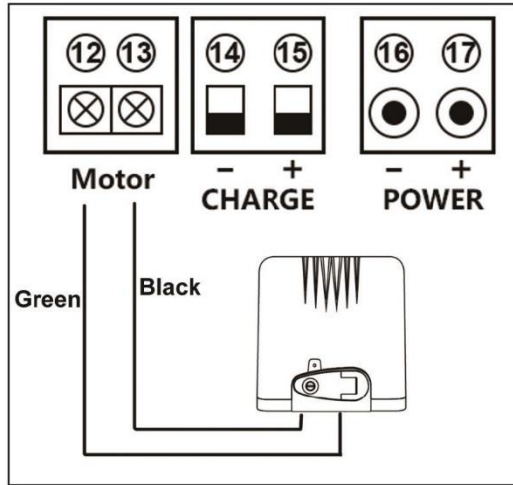

(Fig 22)

When the motor being installed to left of gate , motor wire diagram as picture shows.

Terminal 12 connect the black wire from motor

Terminal 13 connect the green wire from motor

14&15. Charge terminal: use for connect transformer AC24V (when electric system use)

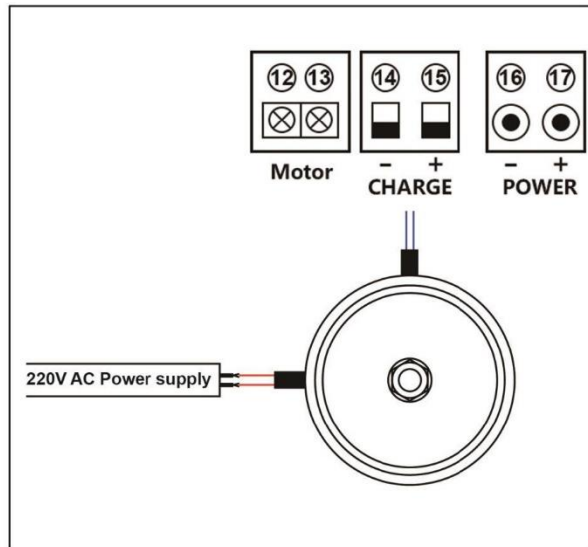

(Fig 22)

Connect terminal 14 to transformer one yellow wire

Connect terminal 15 to transformer another yellow wire

Two red wire from transformer is for connecting 220V power supply.

position of the opener and/or place a few shims between the rack and gate.

2. Manually slide the gate leaf to ensure the rack is properly installed on the gear of the gate opener.

3. The gear rack length must be longer than the actual travel distance of the gate. Cut away any excess gear rack not needed.

Control board Program

Parameter:

1.Board power supply: DC 24V

2.Remote control: Giant customized rolling code

3.Remote control memory: max support 120pcs.

Terminal and diagram of control board instruction(Fig 16):

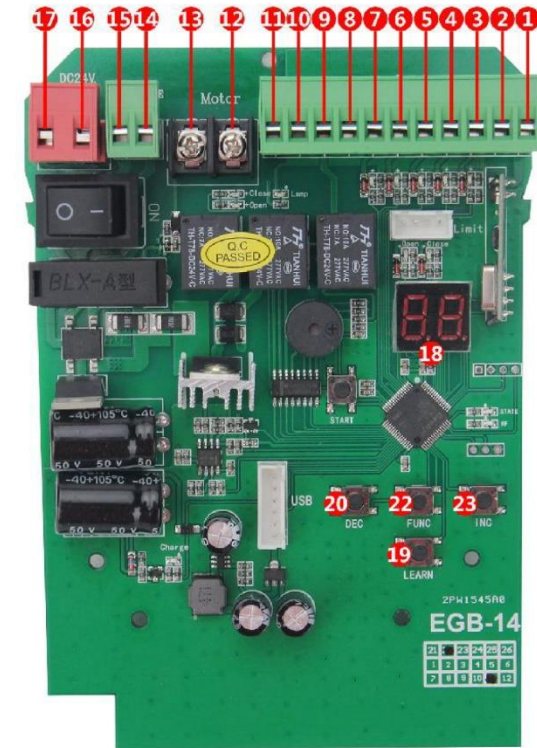

(Fig 16)

Installation diagram of electrical parts.

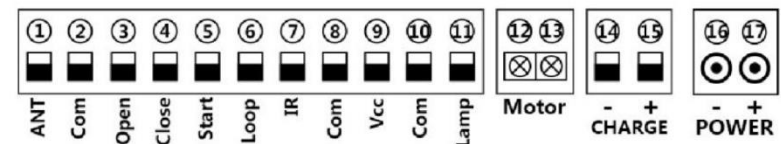

(Fig 17)

1.ANT terminal:Antenna connection

- 2.COM terminal: use for connect COM terminal or GND
- 3.Open terminal: use for connect device that want open gate
- 4.Close terminal: use for connect device that want close gate
- 5.Start terminal: Single button control mode switch, used for controlling gate“open-close-stop-open-close” cyclically (Fig 18)

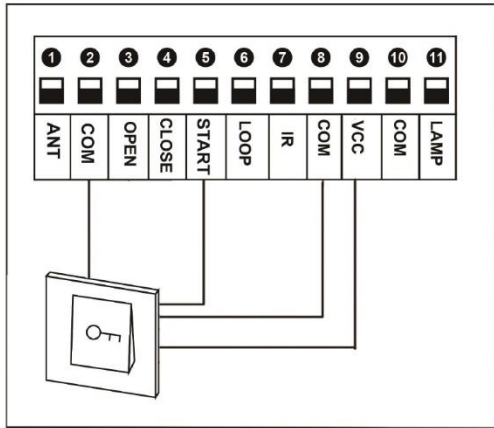

(Fig 18)

- Example for push button;
- Terminal ⑤ and ② connect to push button.
- Terminal ③ and ⑨ to supply power for push button.
- 6.Loop terminal: used for connect loop detector etc device.
- 7.IR terminal :used for connecting photocell. (Fig 18)

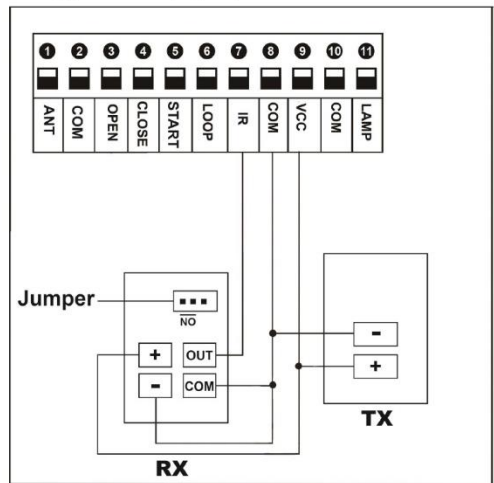

(Fig 19)

- Connect terminal ③ to the “COM “of photocell RX.
- Connect terminal ⑦ to the “OUT “of photocell RX.
- Terminal ⑧ and ⑨ is supplying power for external device.
- So, connect terminal ⑨ to the “+ “of photocell RX and TX.

- Connect terminal ⑧ to the “- “of photocell RX and TX.
- 8.COM terminal: use for connect COM terminal or GND
- 9.VCC terminal: on board power supply for infrared external device etc.
- 10.COM terminal: use for connect COM terminal or GND
- 11. Lamp terminal: use for connect flashing light. Lamp light on when gate running. Output voltage is DC24V

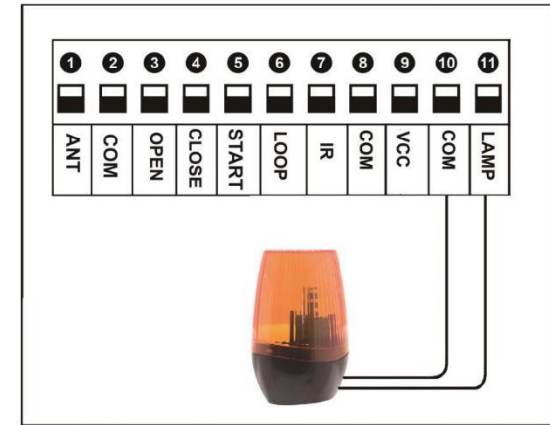

(Fig 20)

Terminal ⑩ and ⑪ is for flashing light

12&13. Motor terminal: use for connect 24VDC motor .

A.Install the motor on the right of gate (factory setting)

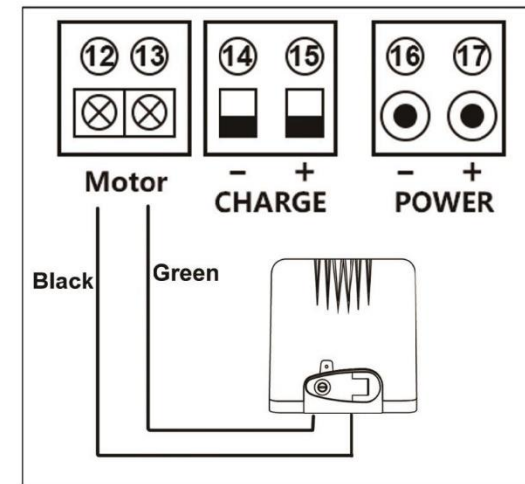

(Fig 21)

- When the motor being installed to right of gate , motor wire diagram as picture shows.
- Terminal ⑬ connect the green wire from motor
- Terminal ⑫ connect the black wire from motor